

Product description

Rockpanel boards for external cladding have been developed for fast, user-friendly and aesthetic applications. Used in façades, detailing, soffits, and fascias. The boards are as workable as wood and as durable as stone. The boards are resistant to weather, temperature and UV. They are fire-safe, made from fully recyclable stonewool and require very low maintenance.

Rockpanel Ply is supplied with a light-grey primer coating and can be given a finish coat in any colour you wish. The top (colour) coat can be site applied or in a paint shop.

Application

Rockpanel board material is especially suited for ventilated construction, providing good building physics, high insulation values and therefore a healthy interior climate.

Rockpanel can be used in new construction and renovation:

- Façade and partly clad buildings
- Soffits and fascias
- Detailing and roofline

Product advantages

Rockpanel board material has some unique features:

- no need to treat edges to protect against moisture
- low in maintenance
- light weight
- can easily be cut to size on site
- does not require pre-drilling
- standard (durable) version suitable for curved facades
- dimensionally stable
- fire-safe
- stonewool fully recyclable

Assortment

Rockpanel Ply is supplied as standard in a light-grey primer coating. The boards can be given a finish coat in any colour you wish.

Properties

Dimensions and tolerances of board material

Board length in mm*	2500/3050		
Board width in mm	1200		
Board thickness in mm	6	8	10
Length/width tolerance in mm	+2/-2		
Thickness tolerance in mm	+ 0,5/-0,5		
Diagonal tolerance in mm	≤ 4		

* For different dimensions, contact Rockpanel for the possibilities.

Material properties

PROPERTY	VALUE	UNIT	STANDARD
MECHANICAL PROPERTIES			
Module of elasticity	3390	N/mm ²	EN 310
Characteristic bending strength	≥ 13,5	N/mm ²	EN 310 and EN 1058 f ₀₅
PHYSICAL PROPERTIES			
Nominal volume density	1000	Kg/m ³	
Nominal area density	6 mm: 6 / 8 mm: 8 / 10 mm: 10	Kg/m ²	
DIMENSIONAL VARIATION			
Linear expansion coefficient	11*10 ⁻³	mm/(m°K)	EN 438-2
Change in length due to moisture at 23°C/50% RH to 23°C/95% RH	< 0,29	mm/m (after 4 days)	
Water uptake via sawn edge after 28 days:			
- At 20°C and 65% RH	< 1,3	%	
- At 2°C and 90% RH	< 0,2	%	

Fire safety

Rockpanel board material is tested according to the standards in force and categorised as a fire-safe building material. As Rockpanel Ply is subsequently given a finish coat this could have an impact on fire performance. As this aspect is beyond our control it is not possible to issue a fire classification for this product.

Installation**Ventilated external-wall systems**

Rockpanel board material is suitable for use in ventilated facades. In this type of facade, the outer facade is constructed as a cavity wall with an inner and outer layer, so that a ventilated space is created between the facade cladding and insulation.

Open facade

Here the use of water-draining sections is avoided, as a result of which some of the rainwater run-off runs into the cavity behind the cladding.

For open joints in a **wooden support structure**, the structure behind the vertical batten should be equipped with a vapour-permeable, water-repellent membrane, non-capillary and UV-resistant. The recommended space between the Rockpanel and the vapour-permeable, water-repellent membrane should be at least 20mm, however in practice it is usually the thickness of the battens ie 28 or 34 mm.

Closed facade

In this construction, the rainwater is diverted as much as possible to the outside of the cladding. The recommended cavity depth for a ventilated cavity should be at least 20 mm, however in practice it is usually the thickness of the battens ie 28 mm or 34 mm.

Fixing

Various means of jointing can be used to fix Rockpanel Ply, such as:

- Non-visible mechanical mounting (concealed filling)
 - Rockpanel ring shank nails; material number 1.4401 or 1.4578 in conformity with EN 10088, 2.1/2.3 x 27 mm PK
 - Staples; material number 1.4301 in conformity with EN 10088, 38 mm long, back 13 mm
- Glued attachment
 - Rockpanel Tack S
- Visible mechanical mounting
 - Rockpanel ring shank nails; material number 1.4401 or 1.4578 in conformity with EN 10088 2.7/2.9 x 32 mm PK
 - Rockpanel Torx screws; material number 1.4401 or 1.4578 in conformity with EN 10088, 4.5 x 35 mm with sub-thread.

Because Rockpanel board material hardly expands or contracts at all, pre-drilling is not necessary.

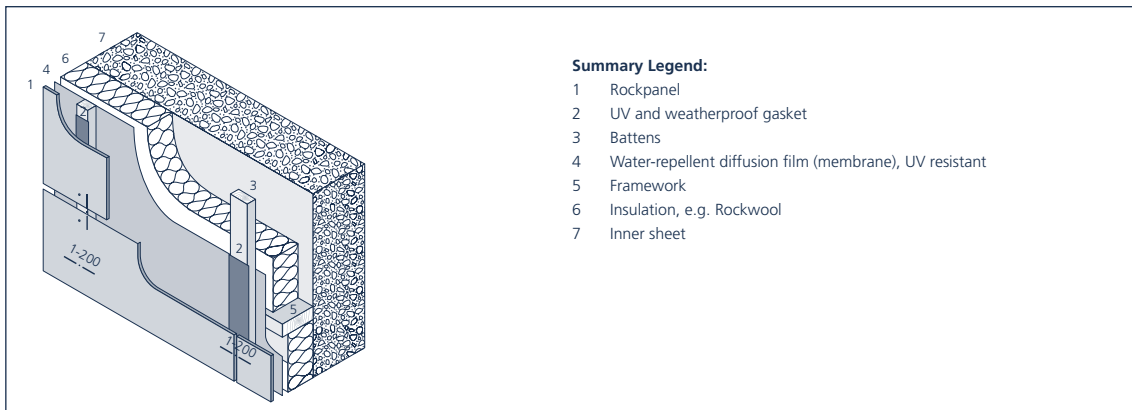

Adhesive installation on wood structures

Adhesive installation of Rockpanel board material should be carried out according to the instructions of the supplier of the adhesive system and under his supervision and warranty conditions. Adhesive installation on a metal support structure or, in the case of wood, on a Rockpanel strip is a more durable implementation than direct adhesive installation on a wooden support structure. See the Rockpanel website for more information and an adhesive supplier with a suitable system.

Attachment distances

Rockpanel board material must be attached to the substructure with Rockpanel installation systems in the case of mechanical installation. In deciding on the substructure, take account of the following:

- the wind load experienced
- maximum attachment distances for the panels
- necessary provisions for ventilation
- the boards must be able to move
- legal requirements
- the height of the building

Consult the following table to see the spacing between points of fastening applicable to mechanical fixing. Always contact Rockpanel in the event of situations that depart from the norm.

The following fixing pattern can be applied as the assumptions like basic windspeed, site-altitude, building height and so on fits to the project or are overestimated:

<p>United Kingdom Basic wind speed ≤ 23 m/s Site altitude < 50 m above sea level Building height ≤ 10 m Distance to the coast > 10 km Span over 2 fields (see drawing) Max permissible deflection 0.85%</p> <p>aR1: 15 mm aR2: 50 mm</p>			
	Span	am Intermediate support	ar Edge support
8 mm			
Rockpanel Torx screw	600 mm	255 mm	470 mm
Rivet AP14-5 x 18-s	600 mm	340 mm	500 mm
6 mm			
Rockpanel Torx screw	400 mm	260 mm	300 mm
Rivet AP14-5 x 18-s	400 mm	290 mm	300 mm

Contact Rockpanel for further guidance if any of the pre-conditions above cannot be met.

For the mechanical mounting use wooden laths or wooden framing at least 28 mm thick for the ring shank nails and at least 34 mm thick for the staples. The width should be 45 mm at the point of an intermediate support and at least 70 mm at the point of a vertical seam. Wood quality should be in accordance with the associated Rockpanel document. The fixing methods can also be used in a chlorine-rich environment, such as by the coast.

Provided account is taken of the underlying structure, Rockpanel Ply can, under certain conditioning, be applied seamlessly (see detail 1-209), with an open joint, or caulked. If butting board edges directly together then it is wise to bevel the board edges. In case of seamless applying and open joints, protect the underlying woodstructure against damp by using a flat UV-resistant and weatherproof joint sealing strip. When using a sealant, do not use silicone sealant (this repels paint!), but a sealant that can be painted on or over, such as Simson Hybridtop. Pre-treat the sawing edges with MSP Transparent primer. To counteract attachment to the structure, a PE strip should be applied.

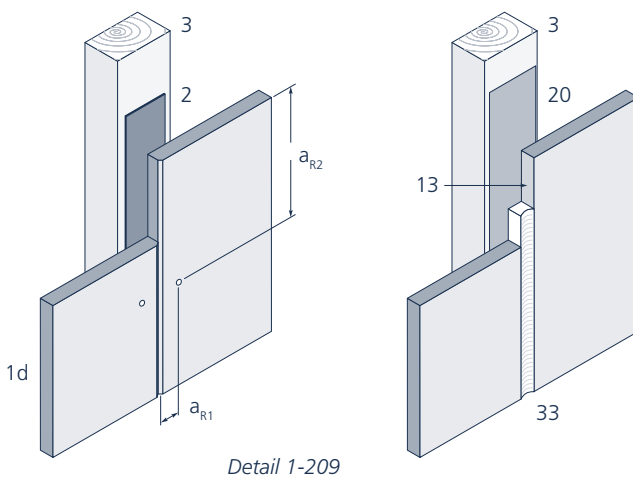

Connections

Jointless and with sealant.

- 1d Rockpanel Ply
- 2 Weather-resistant joint sealing gasket
- 3 Lathing, dimensions 34 x 45 mm and shank nails the minimum thickness is 28 mm)
- 13 Simson Primer MSP Transparent
- 20 Anti-adhesive layer, e.g. strip PE film
- 33 Sealant: e.g. Simson HybridTop (paintable)
- a_{R1} Edge distance min. 15 mm
- a_{R2} Edge distance min. 50 mm

Joints and board connections

Take account of the following in making joints and board connections.

- Rockpanel is dimensionally stable, and therefore resistant to changes in length and width. When constructing, keep in mind that other materials expand or contract or varying degrees compared to Rockpanel boards.
- Boards, assembly and building tolerances play an important role in the joint detail.
- Apply joint tape to the seams to protect the back construction against weather influences.
- Design joints > 5mm, so that rainwater drops off, and is not hold by the capillary effect.
- The surface of the aeration and vent hole shall comply with the local building regulations.

Handling

Sawing

When working with Rockpanel products, as a rule the same guidelines apply as if you were working with wood products.

- hand saw, for example a hardpoint hand saw
- circle saw, for example a fine-toothed tungsten carbide saw blade e.g. ø 300 mm, 48 teeth
- fretsaw, for example a fine-toothed metal saw blade or a tungsten grit saw blade

Drilling

The boards do not need to be pre-drilled before delivery and can be mechanically installed directly on the construction site.

Painting advice

Rockpanel Ply is primed with an undercoat used in the wood processing industry. In principle all paint systems for the finishing industry may be used to give the board a finish coat, provided the paint manufacturer indicates that the paint is suitable for Rockpanel. Therefore, you should always ask your paint supplier about the correct choice of paint and edge finishing.

For maintenance, we also refer to the paint manufacturer's instructions.

Edge finishing

Rockpanel board material is insensitive to moisture. Finishing sawed edges and edge finishing are not needed. Chamfering is easy using the non coated surface of a leftover Rockpanel strip to lightly sand the edge. The side edges can be painted if needed for aesthetic reasons.

Storage

Rockpanel is insensitive to moisture. Nevertheless, it is recommended that the board material be stored dry, flat, frost-free and protected on a flat pallet. Never stack more than 2 pallets on top of each other. The boards should be raised for handling; it is not advisable to slide them over each other. Protective foam sheets should also be placed between the boards to protect the surface layer after, for example, machining.

Maintenance

Rockpanel board material is as durable as stone, resistant to temperature and weather influences, and therefore low-maintenance. If desired, the painted board material can be cleaned with, for example, a car shampoo or an all-purpose cleaner, diluted as indicated on the package. When you clean the boards, always bear in mind the finish (colour) coat that was applied and the paint supplier's recommendations.

Specifications and CAD drawings

Specifications and CAD drawings can be downloaded from www.rockpanel.co.uk.

Availability

Consult the dealer locator on www.rockpanel.co.uk for a Rockpanel distributor in your area.

Sustainability

Rockpanel is a sustainable building material throughout the material's useful life.

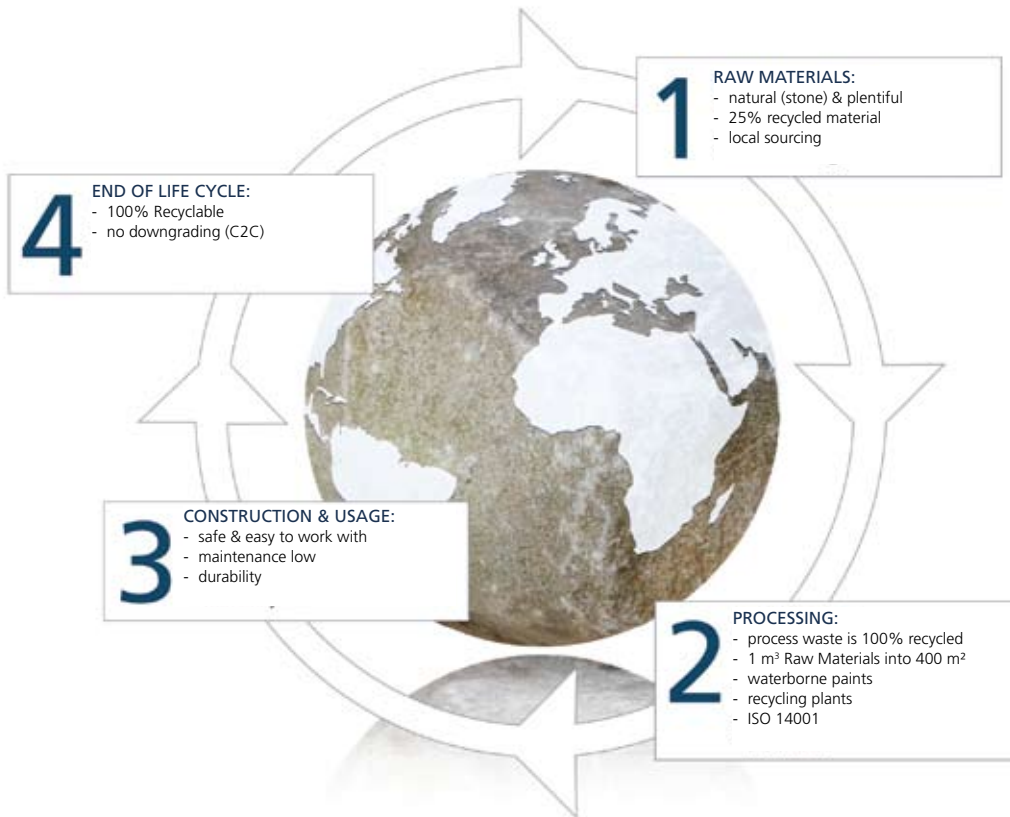

Published October 2010. This publication supersedes and replaces all previous publications. Subject to alterations. All data are intended to serve as general information about our products and their possible uses, and do not imply a guarantee that these products have certain properties. Therefore, no rights may be derived from the content of this publication. © 2010

Rockwool Rockpanel B.V. – Wern Tanw, Pencoed – Bridgend CF35 6NY